



CR-5/CR-7 CLASSIC SERIES ASSEMBLY INSTRUCTIONS

Ref# 2010-156, revised 4-27-10 by R.J.C.

READ ALL INSTRUCTIONS THOROUGHLY
BEFORE YOU BEGIN.

CHECK ALL PARTS

- Be certain there are no missing parts.
- Be certain all required tools are available.

REQUIRED TOOLS

- 1/2-inch and 3/4-inch Hex Drive and Wrench.
- Ratchet or Breaker Bar.
- Towels (or something soft) to rest components on during assembly to protect the finish

ASSISTANCE REQUIRED

- 2 people recommended to assemble product.
- Necessary to handle, fit, and secure components.
- Heavy lifting.

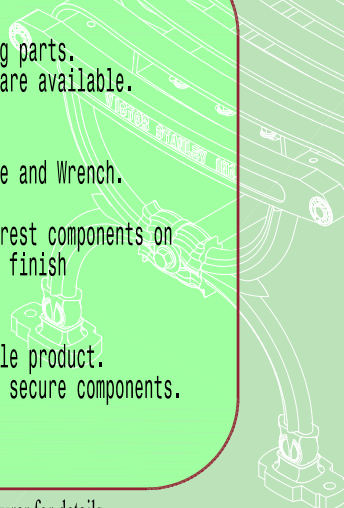

All specifications are subject to change. Contact manufacturer for details.

DELIVERY, STORAGE, and HANDLING

- Delivery: Deliver products to site in manufacturer's original, unopened containers and packaging. Upon delivery, examine packages immediately to ensure all products are complete and undamaged.
- Storage: Store products in a protected, dry area in manufacturer's unopened containers and packaging
- Handling: Protect product's finish from damage during handling and installation.

INSTALLATION

- Clearance for 3/8-inch (9.5mm) anchor bolts (anchor bolts not provided by Victor Stanley, Inc.)
- Mounting: It is not recommended to locate anchor bolts until bench is in place. This Victor Stanley, Inc. product must be permanently affixed to the ground. Consult your local codes for regulations.

PROTECTION

- Protect products prior to installation by having them remain in the manufacturer's packaging and container.







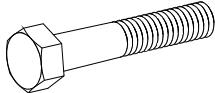

Should you have any problems, please contact Victor Stanley, Inc.

www.victorstanley.com

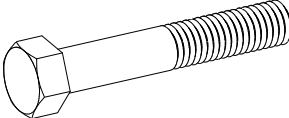

PARTS LIST

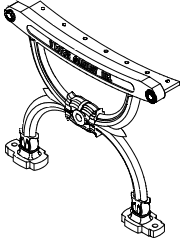
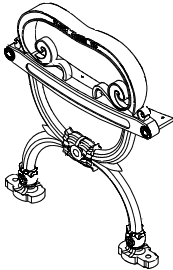
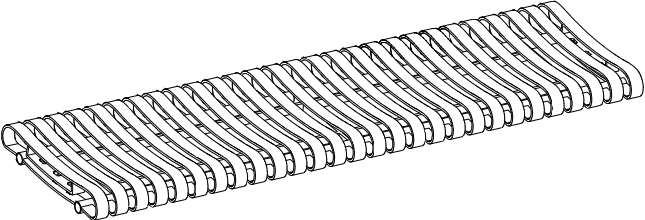
<p>Ax6 5/16" x 1-3/4" HEX HEAD BOLT</p> 	<p>Bx12 5/16" FLAT WASHER</p> 	<p>Cx6 5/16" LOCK WASHER</p> 	<p>Dx6 5/16" NUT</p> 
<p>Ex1 RUNG BAR</p> 	<p>Fx2 1/2" x 3" HEX HEAD BOLT</p> 		<p>Gx2 1/2" FLAT WASHER</p> 
<p>Hx2 C-5 CASTING</p> 		<p>Ix2 C-7 CASTING</p>  <p style="text-align: center;">OR</p>	
<p>Jx1 SEAT SECTION</p> 			

TOOLS REQUIRED (NOT PROVIDED)



DRIVER or WRENCH
 *This symbolizes when to use TOOL to tighten.

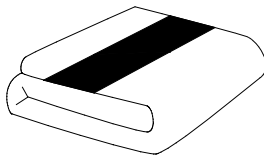

TOWELS
 (or something soft to protect finish)



HANDS
 *This symbolizes when to use HAND to tighten.



STEP #1 Remove all parts from their boxes and bags, and place on a soft surface (towels, cardboard, grass, ect.) to prevent scratching.

STEP #2 Set the two legs upright then lift the seat section and slide the castings into the slot shown on either end.

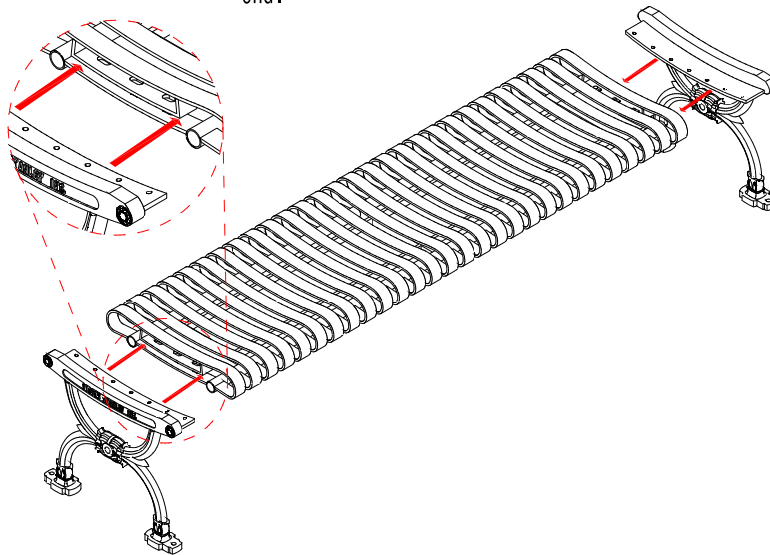

STEP #3 Lift the rung bar into place and secure using the 1/2" bolt and washer configuration shown. Note: Only hand tighten at this stage.

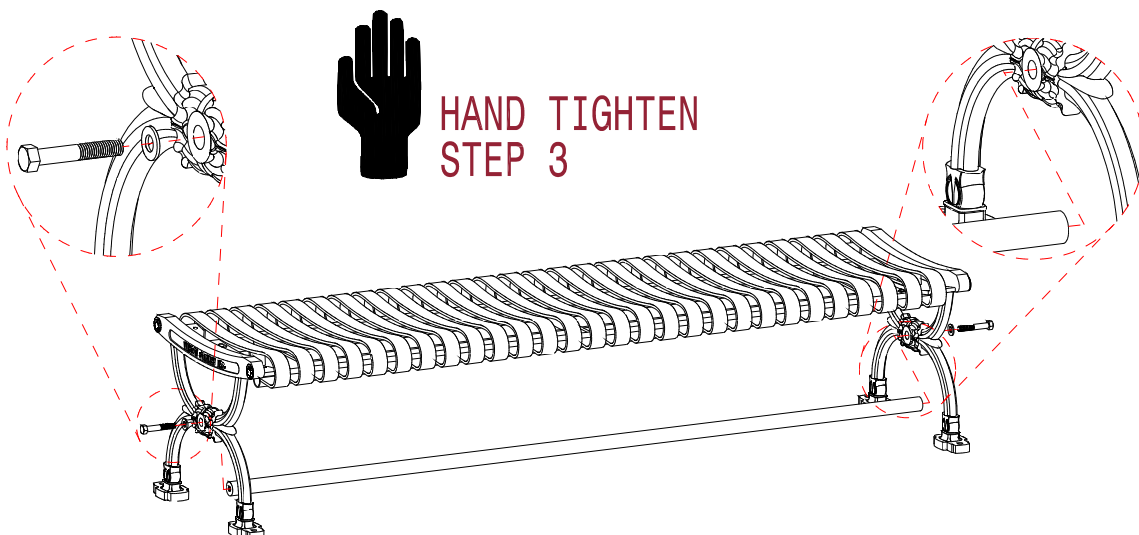



STEP #4

Secure the lip of one casting to one end of the seat section using the 5/16" bolt configuration shown to the right. Repeat on the opposite end.

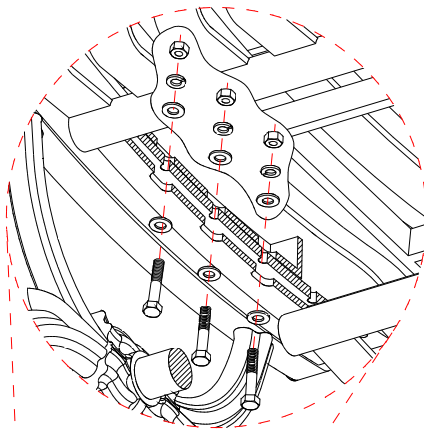

**HAND TIGHTEN
STEP 4**

For step #4 use the bolt assembly shown below:

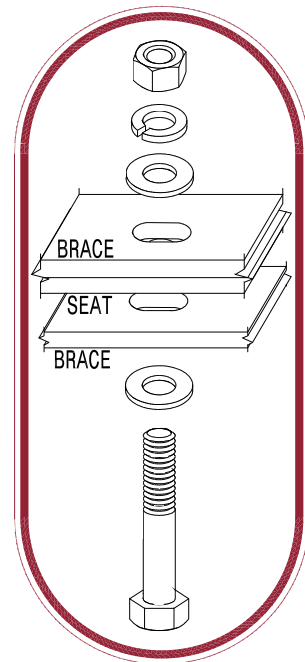

STEP #5

Carefully inspect the bench from front and back to ensure the legs of the bench are standing straight. Once everything is straight and aligned properly, tighten all bolts in the order the bench was assembled.



**TOOL TIGHTEN
STEP 5**



FINAL PRODUCT

CR-5 CLASSIC SERIES

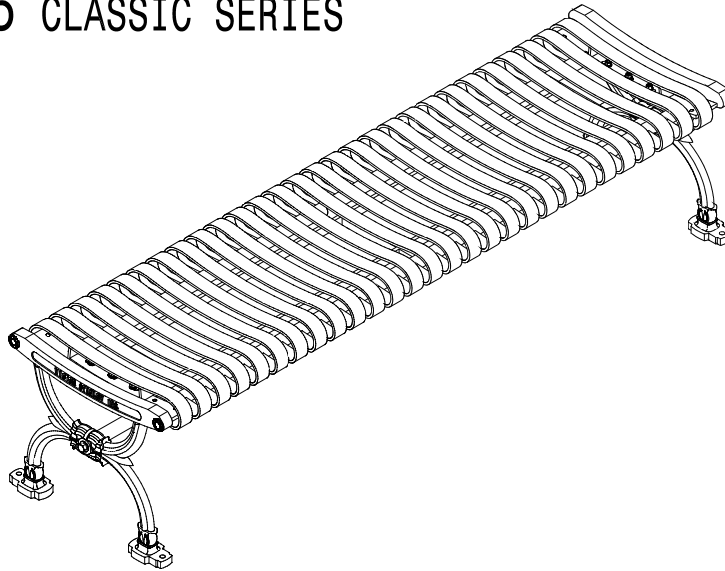

CR-7 CLASSIC SERIES

